



640005-00

25-R & F-25-R

FALCON®

Rim Exit Device
Dispositivo de salida con montura
Appareil de sortie du rebord

Installation Instructions
Instrucciones de Instalacion
Notice d'Installation

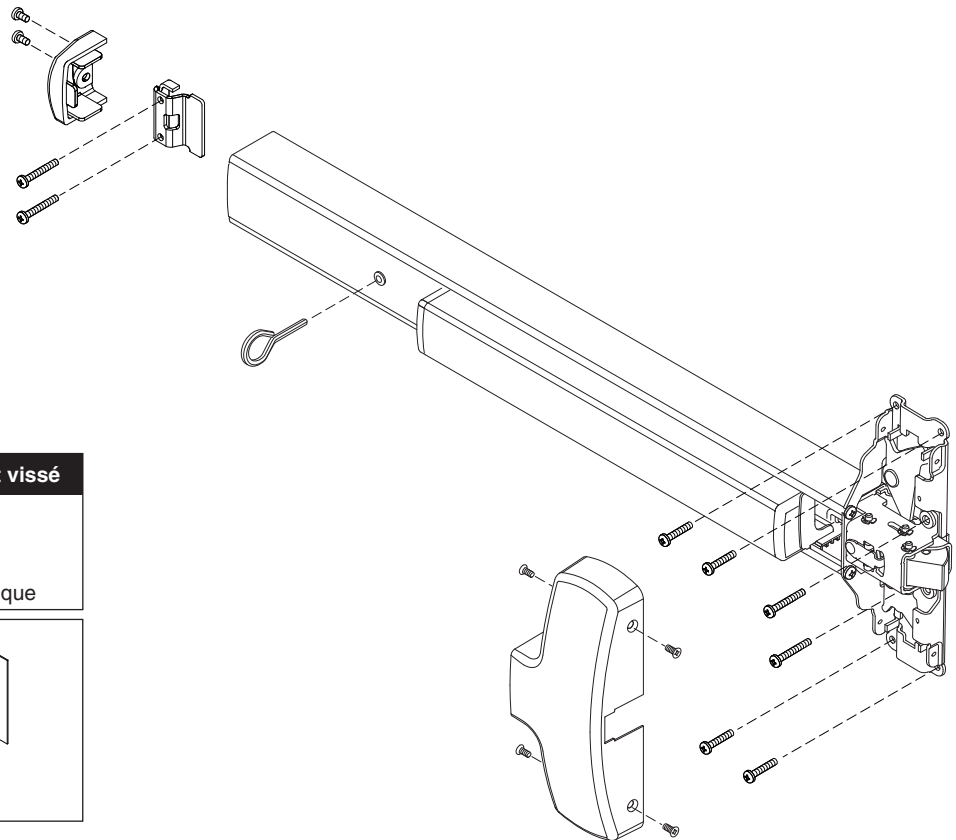
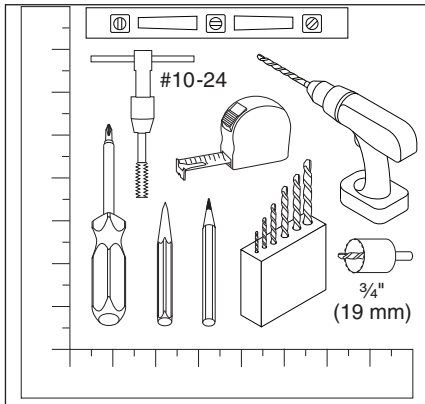

Dogging Key **Llave de trinquete** **Œillet vissé**
Use to lock down pushbar
Utilicelo para asegurar hacia abajo la barra de empuje
Utilisé pour verrouiller la barre antipanique

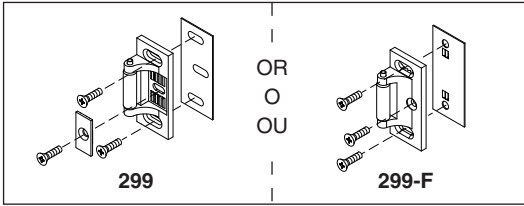

! If sexbolts are in box, see Sexbolt Preparation on back page
Si los pernos macho-hembra se encuentran en la caja, consulte preparación de pernos macho-hembra en la página posterior
Si les colonnettes sont dans la boîte, voir la préparation de colonnettes au verso de la page

1 Draw Exit Device Centerline (☿)
Sacar la línea central del dispositivo de salida (☿)
Tracer l'axe du dispositif de sortie (☿)

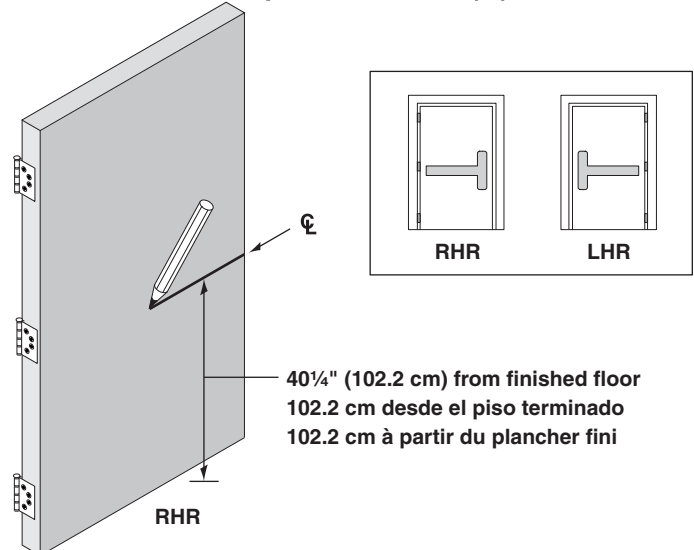

2 Mark 2 Slots
Marque 2 ranuras
Marquer 2 fentes

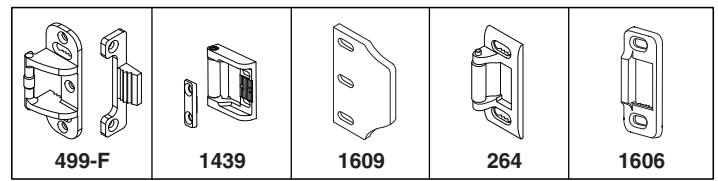
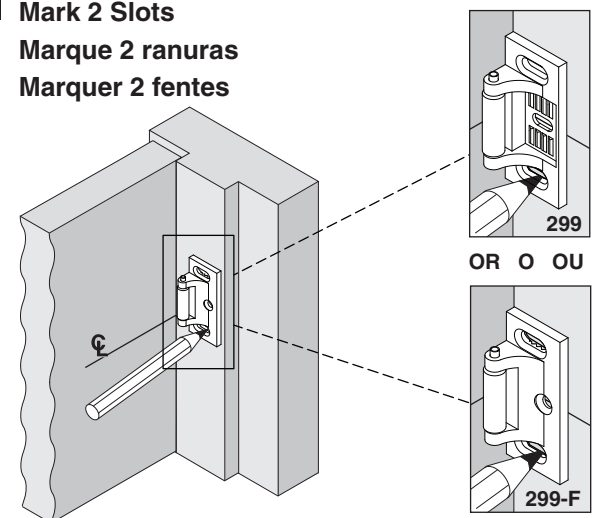

Customer Service **Servicio al cliente** **Service à la clientèle**
1-877-671-7011 www.allegion.com

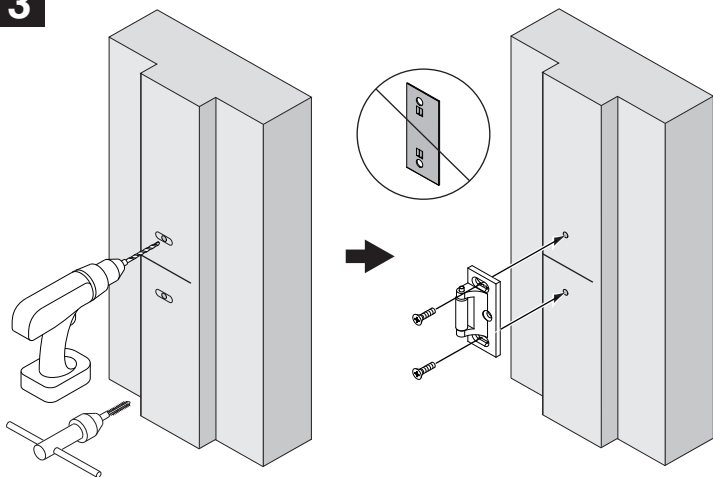
3

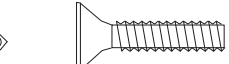
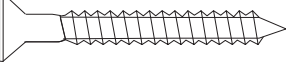
Metal	Metal	Métal
#25	#10-24	
----- OR O OU -----		
Wood	Madera	Bois
1/8" (3 mm)	1" (25 mm) deep/profundidad/ profondeur	

4

Draw Vertical Centerline (☉)
Sacar línea central vertical (☉)
Tracer l'axe vertical (☉)

Center point on plastic template
 Punto central en la plantilla de plástico
 Placer la pointe de centrage sur
 le gabarit de plastique

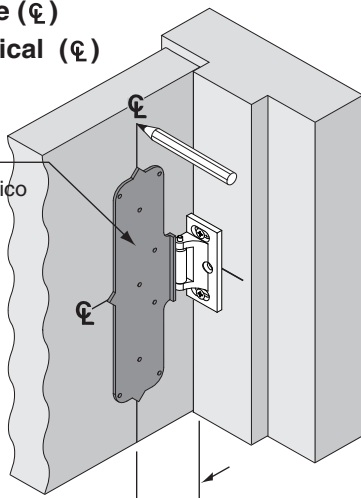

☉ parallel with door edge
 paralelo con el borde de la puerta
 parallèlement au bord de la porte

5

Mark 7 Holes
Marque 7 orificios
Marquer 7 orifices

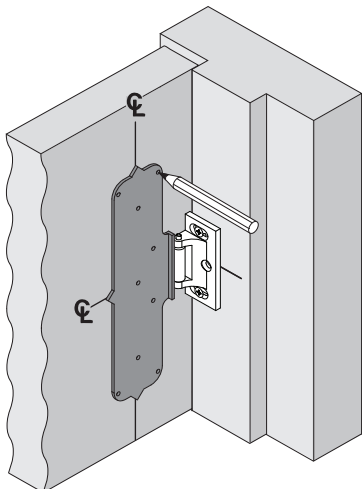
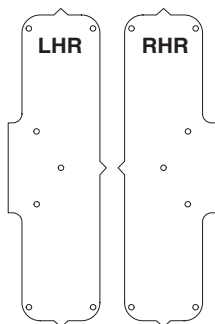
**6**

If Using the NL-OP (Cylinder Only) Option, See Their Instructions

Si utiliza la Opción NL-OP (sólo Cilindro), consulte las instrucciones

Si vous utilisez l'option NL-OP (cylindre seulement), veuillez en consulter les instructions

Note: NL-OP function does not require the 3/4" hole shown in step 7, skip to step 8

Nota: La función NL-OP no requiere el agujero de 19mm que se muestra en el paso 7. Saltee hasta el paso 8

Note : La fonction NL-OP ne nécessite pas le trou de 19mm po illustré à l'étape 7. Passez à l'étape 8

7

Cut 3/4" (19 mm) Center Hole
Corte 19 mm Orificio central
Couper po 19 mm au centre

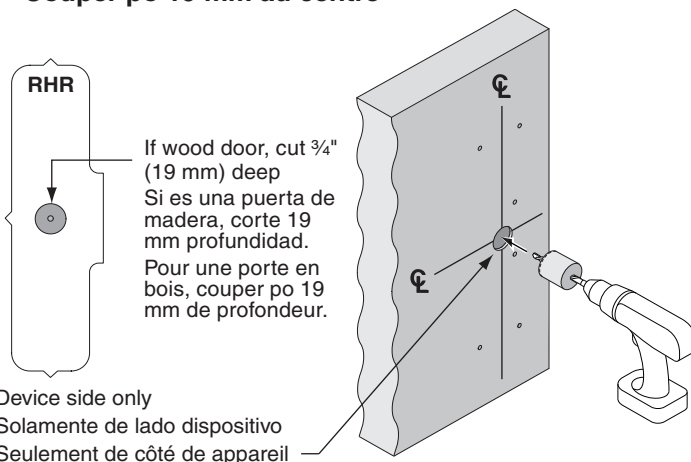
**8**

Prepare 2 Holes
Prepare 2 orificios
Préparer 2 orifices

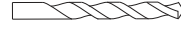
Metal	Metal	Métal
#25		
#10-24		
----- OR O OU -----		
Wood	Madera	Bois
1/8" (3 mm) X 1" (25 mm)		
		

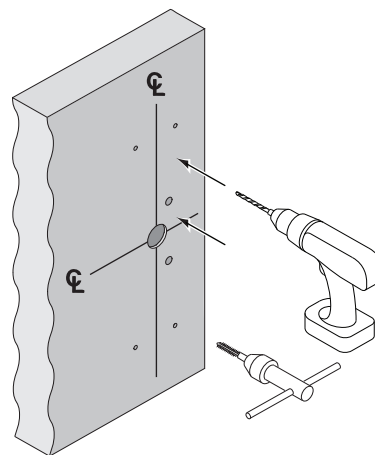
**9**

If Installing Trim, Go To Trim Instructions
Sin instala la moldura, Vaya a instrucciones de moldura
Pour l'installation d'une garniture, voir les instructions de garniture

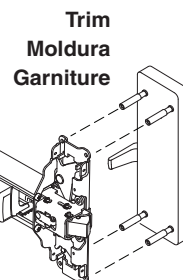

10 Prepare 4 Holes*
Prepare 4 orificios*
Préparer 4 orifices*

Metal Metal Métal

#25

#10-24

--- OR O OU ---

Wood Madera Bois

1/8" (3 mm) X 1" (25 mm)

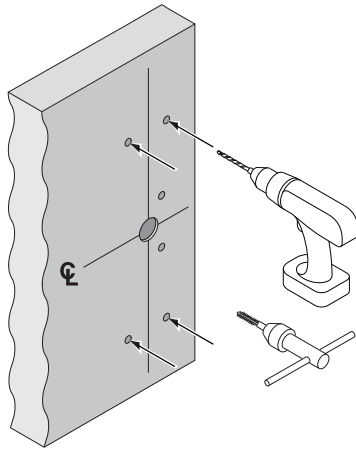

*If using trim, holes may have been drilled already
*Si utiliza la moldura, los orificios ya tienen que estar perforados
*Les orifices peuvent être déjà percés si vous utilisez une garniture

12

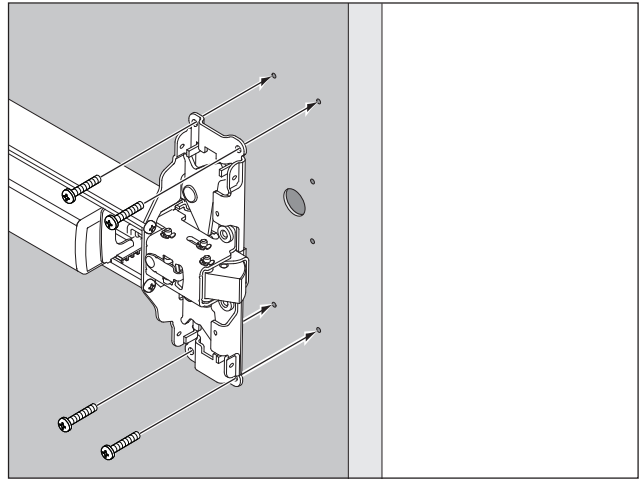

Thru-bolting Trim
Moldura apernada
Vissage transversal
de garniture

OR
O
OU

Surface Mount
Montaje de la superficie
Montage en surface

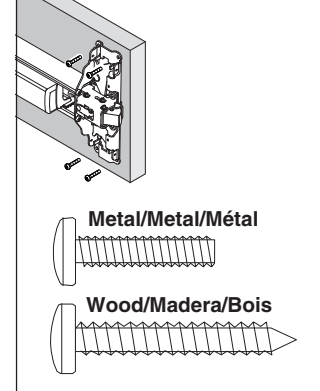
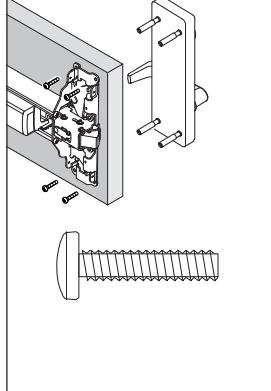

11 If Necessary, Cut Device
Si es necesario, corte el dispositivo
Couper le dispositif si nécessaire

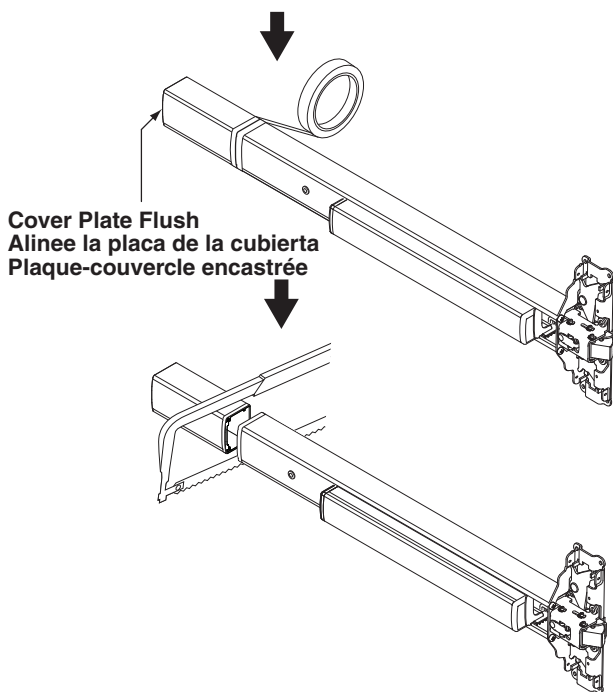
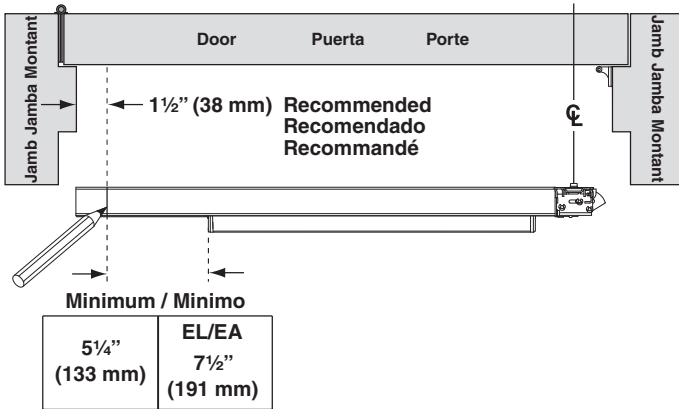

13 Mark and Prepare 2 Holes
Marque y prepare 2 orificios
Marquer et préparer 2 orifices

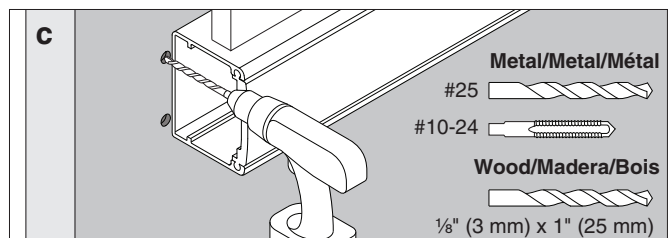
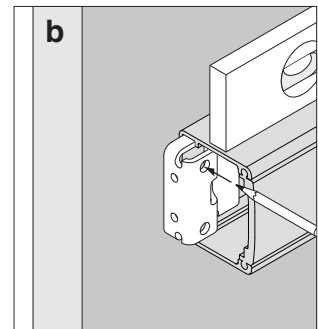
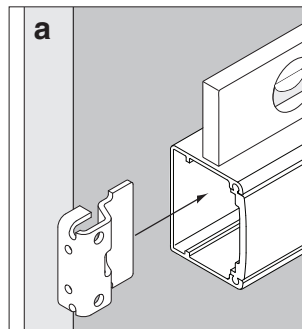

14

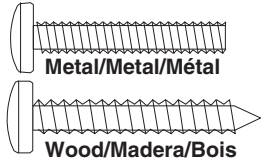
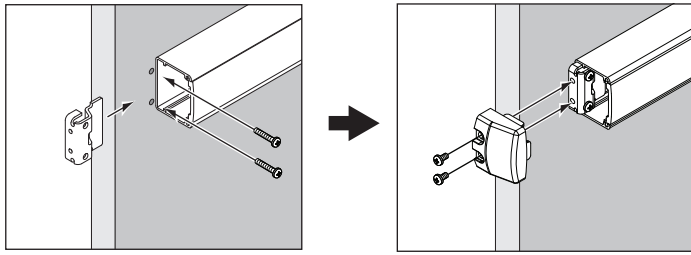

15

Install Required Support Screws
Instale los tornillos de soporte que se requiere
Installer les vis de support

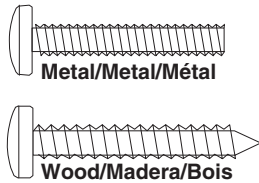
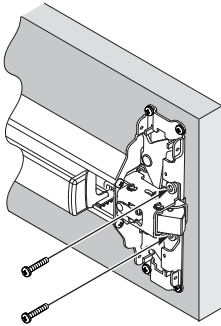

16

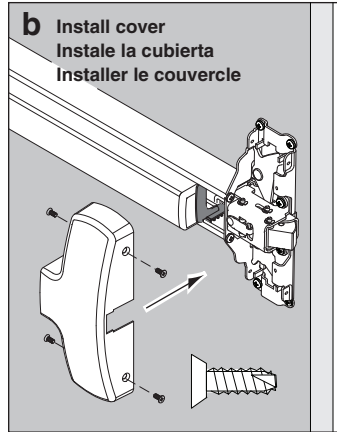
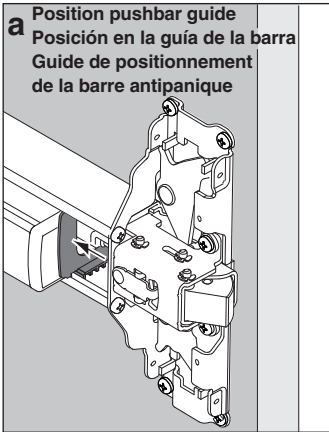

17

Check Dimension
Verifique las Dimensiones
Vérifier la dimension

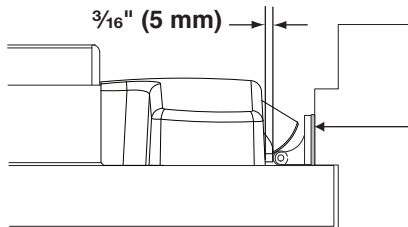

Shim as needed
 Calce conforme
 sea necesario
 Caler au besoin

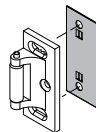

18

Install Support Screw
Instale el tornillo de soporte
Installer la vis de support

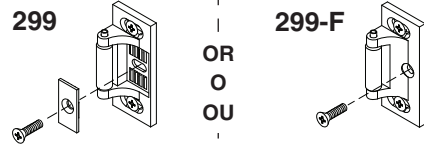

Metal	Metal	Métal
#25	#10-24	
OR O OU		
Wood	Madera	Bois
1/8" (3 mm)	1" (25 mm) deep/profundidad/ profondeur	

Sexbolt Perno macho-hembra Colonnette
Preparation Preparación Préparation



If sexbolts are in box, during steps 8, 10, & 13 prepare holes and install them as shown below



Si los pernos macho-hembra se encuentran en la caja, durante los pasos 8, 10 y 13 prepare los orificios

Si les colonnettes sont dans la boîte, préparer les orifices pendant les étapes 8, 10 et 13

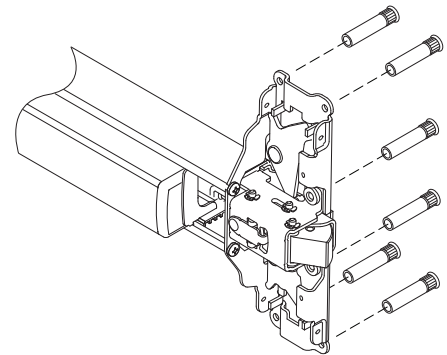
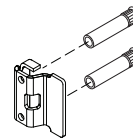
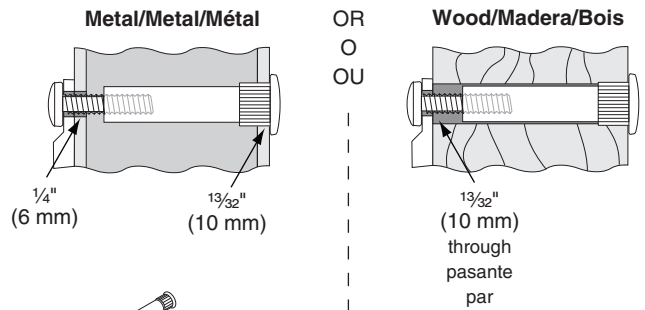

Customer Service Servicio al cliente Service à la clientèle

1-877-671-7011

www.allegion.com



© Allegion 2014
 Printed in U.S.A.
 640005-00 Rev. 01/14-c