

INDEX

TOOLS	2
INSTALLATION PREPARATION	2
FOR LOCK LESS CYLINDER ONLY	4
INSIDE OF LOCK	5
TM381 Vestibule Function ONLY	5
TM561 Classroom Function ONLY	6
TM575 Classroom Security Function ONLY	7
LEVER REMOVAL	8
ROSE REMOVAL	8
LOCK FUNCTIONAL TESTING	9

Y Cylinder and Tailpiece Options			
Outside for TM381, TM501, TM511, TM571, and TM581		Inside for TM381, outside for TM561, inside and outside for TM575	
Full Size IC (FSIC)	Tailpiece	FSIC	Tailpiece
Small Format IC (SFIC)	Tailpiece	SFIC	Tailpiece
Standard Cylinder (KIL)	Tailpiece	KIL	Tailpiece

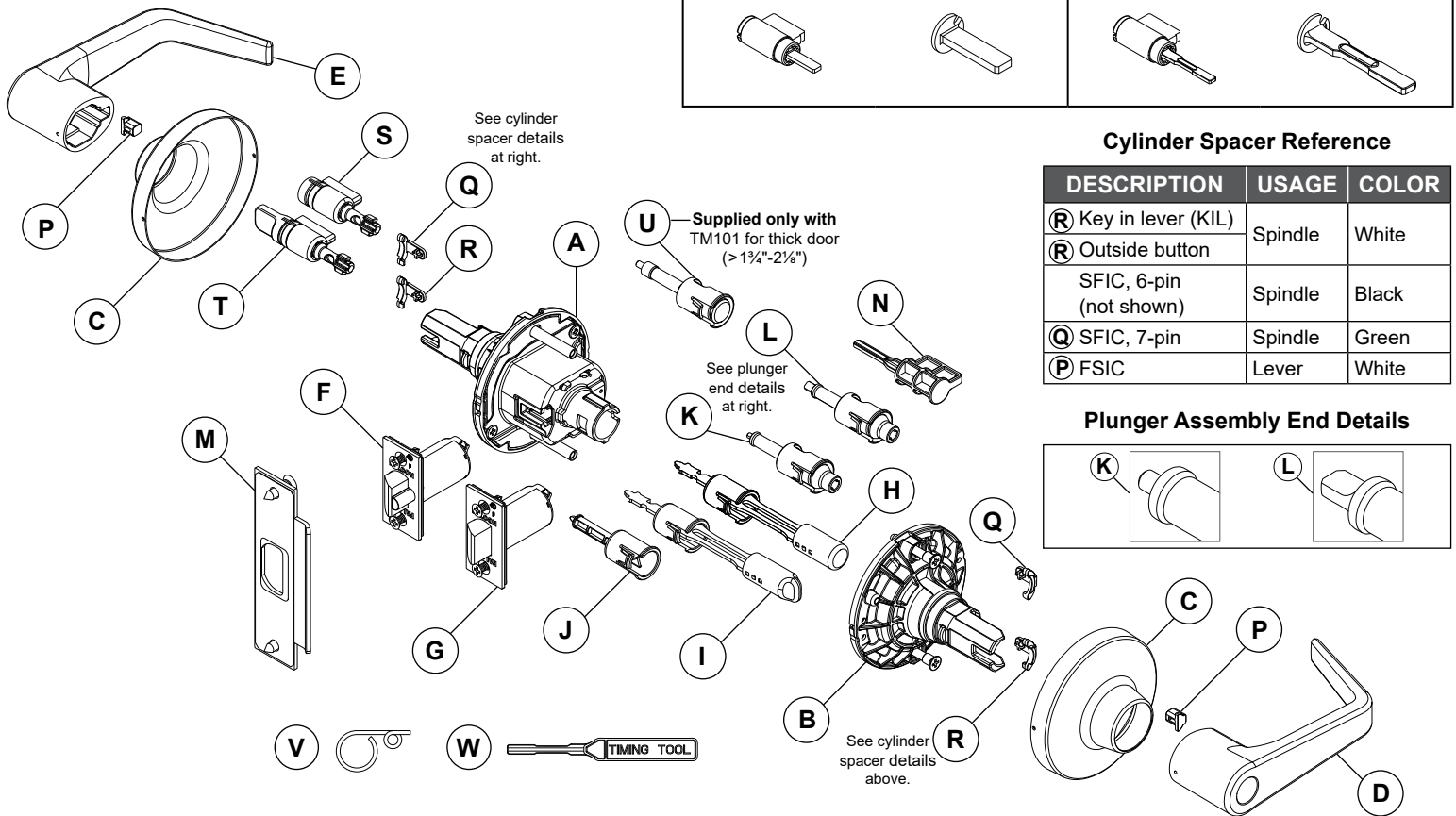

Cylinder Spacer Reference

DESCRIPTION	USAGE	COLOR
R Key in lever (KIL)	Spindle	White
R Outside button		White
SFIC, 6-pin (not shown)	Spindle	Black
Q SFIC, 7-pin	Spindle	Green
P FSIC	Lever	White

Plunger Assembly End Details

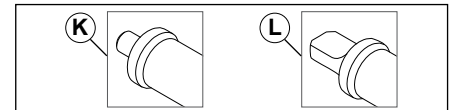

- | | |
|---|---|
| A Chassis/Outside Spring Cage/Spindle Assembly | L Plunger Assembly, Classroom and Classroom Security (TM561, TM575) |
| B Inside Spring Cage/Spindle Assembly | M Strike Assembly |
| C Rose | N Dummy Cylinder (TM561) |
| D Inside Lever | P Cylinder Spacer, FSIC |
| E Outside Lever | Q Cylinder Spacer, SFIC (7-pin spacer shown) |
| F Dead Latch Assembly (TM381, TM501, TM511, TM561, TM571, TM575, TM581) | R Cylinder Spacer, KIL and Privacy Turns |
| G Spring Latch Assembly (TM101, TM291, TM301) | S Outside Button Privacy Function (TM301) |
| H Plunger Assembly, Push Button (TM291, TM301, TM501, TM571) | T Outside Button Privacy/Hospital Function (TM291) |
| I Plunger Assembly, Push-Turn Button (TM511) | U Plunger Assembly, Passage (TM101) for Thick Door Application ONLY |
| J Plunger Assembly, Storeroom Function (TM581) | V Pin Wrench, included |
| K Plunger Assembly, Vestibule (TM381) | W Timing Tool, included (TM381, TM561, TM575 only) |
| | Y Cylinder (TM381, TM501, TM511, TM561, TM571, TM575, TM581) |

TOOLS

Tools required:



Optional tools:

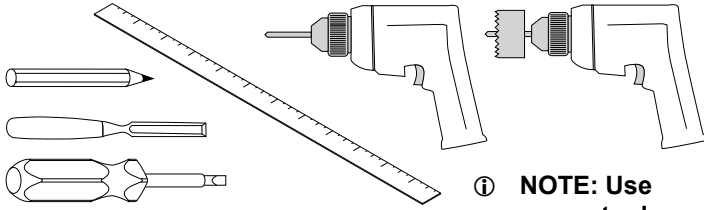

Timing tool (included)
TM381, TM561, and
TM575 only



Pin wrench
(included)

① **NOTE: Use power tools for door preparation only. DO NOT use power tools for lock installation.**

INSTALLATION PREPARATION

Door preparation:

Before installation, check the door for proper preparation.

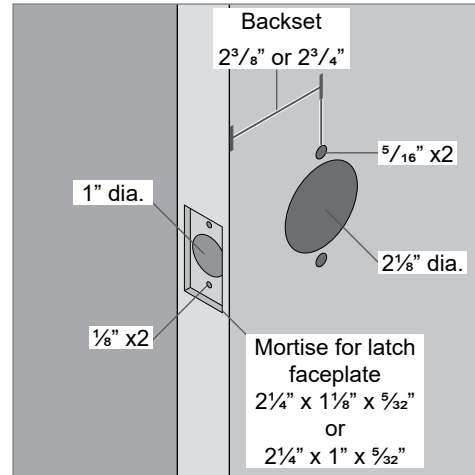

To prepare a door, use the template included in the package with the lock. For additional information, visit www.allegion.com/us or contact technical support at 877-671-7011 (U.S.) or 800-900-4734 (Canada).

1 Install strike

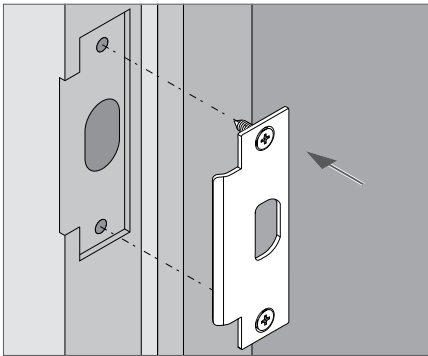

2 Install latch

2a If latch has sleeve, remove for 7/8" latch bore ONLY.

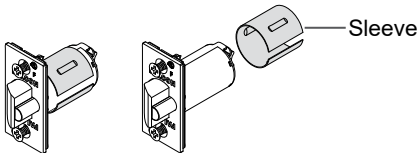

2b Install latch with bevel facing toward the door stop.

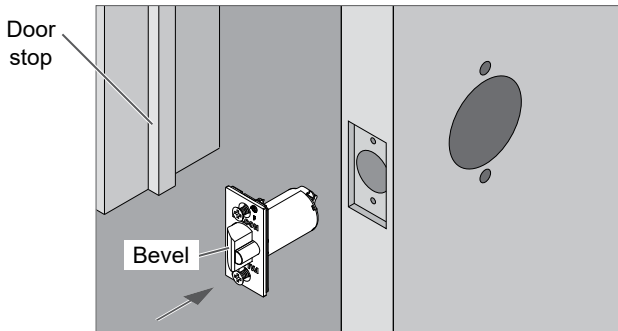

Note: For installation on unreinforced hollow metal doors, use of door spacer (part number 24483760) is recommended.

3 Install chassis/outside spring cage assembly

Slide faces toward door edge.

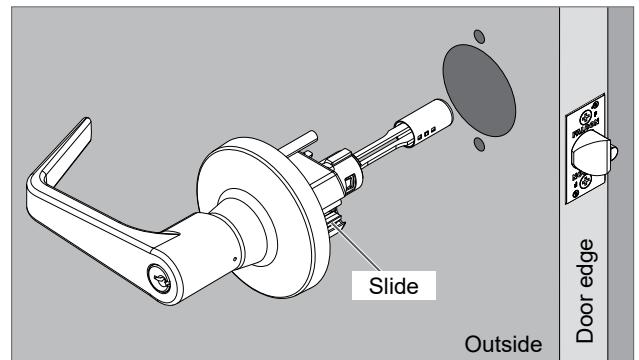

TM501 with Key-in-Lever cylinder shown

IMPORTANT! Latch prongs fit above and below the slide and inside the chassis housing.

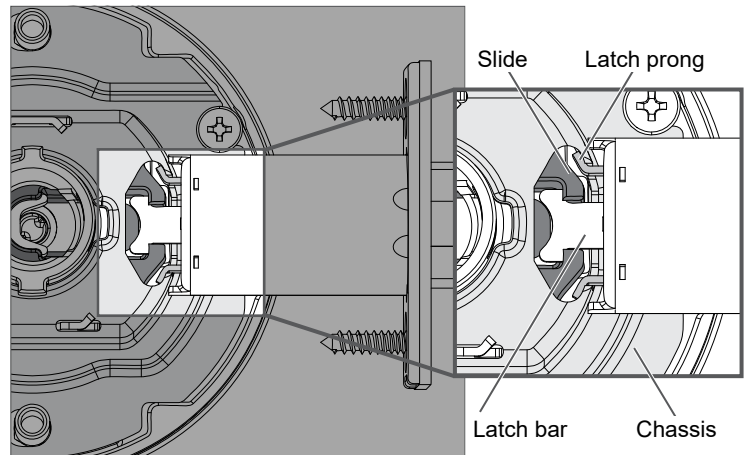

① **NOTE:** For locks ordered "less cylinder" or for IC (Interchangeable Core) cylinders, see "[For Lock Less Cylinder Only](#)" on page 4 for instructions.

4 Install inside spring cage assembly

Fully tighten mounting screws.
Lever catch faces door edge.

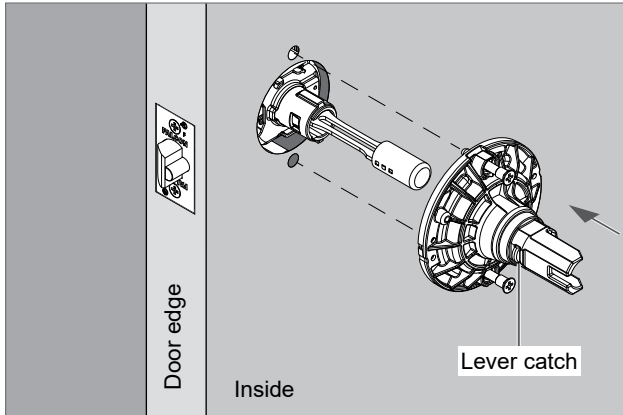

TM501, TM571 shown

5 Install inside rose

5a Align the indent on the rose with the upper notch on the spring cage.

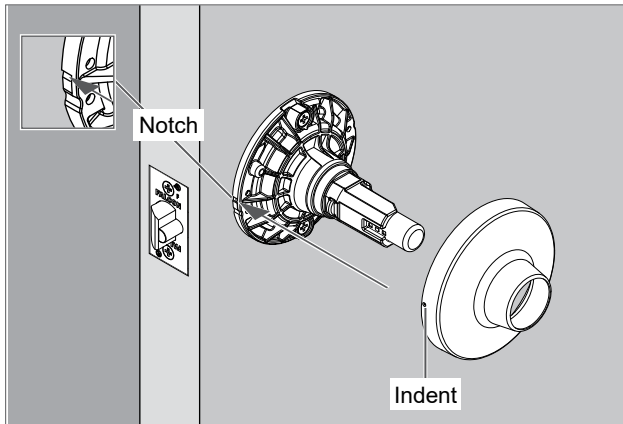

TM501, TM571 shown

5b Place the indent on the notch with the opposite side of the rose angled slightly away from the spring cage as shown. Then, press the other side of the rose into place. You should hear a click as the rose is pressed into place.

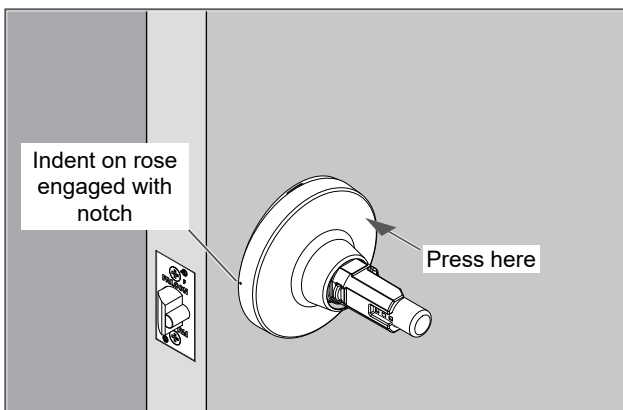

6 Install inside lever

FOR FUNCTIONS TM101, TM291, TM301, TM501, TM511, TM571, AND TM581 ONLY :
(For other functions, see note below.)

Push the inside lever onto the spindle.
Be sure to engage the lever catch.

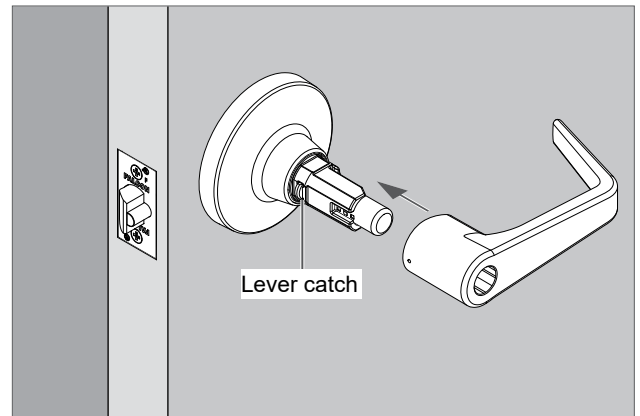

TM501, TM571 shown

① **NOTE: FOR FUNCTIONS NOT LISTED ABOVE:**
see page 5 for [TM381](#) function
see page 6 for [TM561](#) function
see page 7 for [TM575](#) function

[Return to INDEX](#)

FOR LOCK LESS CYLINDER ONLY

INSTALL OUTSIDE CYLINDER (Skip if cylinder is already installed)

For all cylinders, rotate the outside keycam driver.

All functions EXCEPT TM571

Insert flat screwdriver into keycam driver and rotate clockwise until it stops.

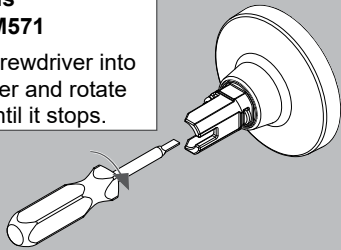

Correct position

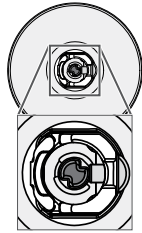

TM571 Function ONLY

Insert flat screwdriver into keycam and rotate clockwise until it stops.

For **KIL cylinder**, rotate counterclockwise slightly.

For **IC cylinder**, rotate counterclockwise until keycam is at 45 degree angle.

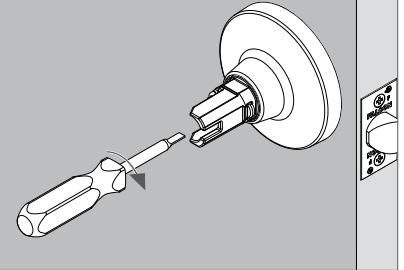

FOLLOW STEPS BELOW FOR APPLICABLE CYLINDER TYPE.

FOR KIL (Key in Lever) CYLINDER:

1. Place the cylinder assembly into the lever.
2. Insert the key and rotate 90 degrees clockwise.

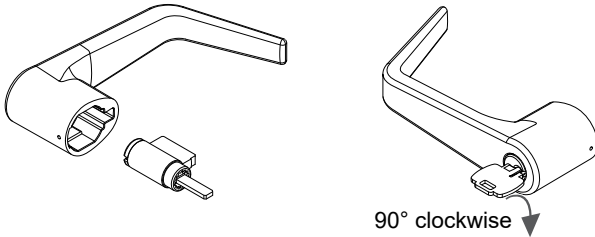

3. With key still rotated 90 degrees clockwise, push outside lever onto the spindle. Be sure to engage the lever catch. Spacer must be installed on spindle.

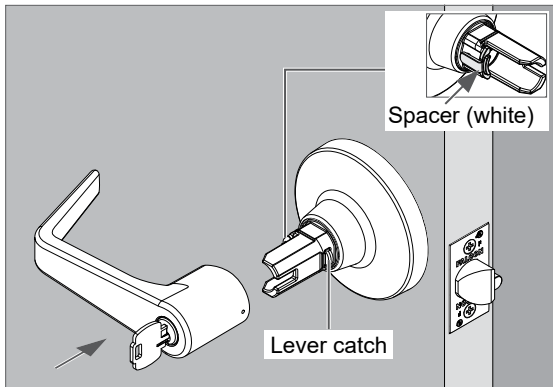

4. Rotate the key counterclockwise to starting position and remove it from the cylinder.

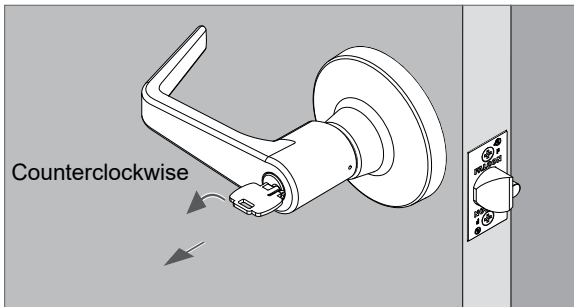

FOR IC (Interchangeable Core) CYLINDER:

1. If the outside lever is not installed, push the lever onto the spindle. Be sure to engage the lever catch. Spacer must be installed.

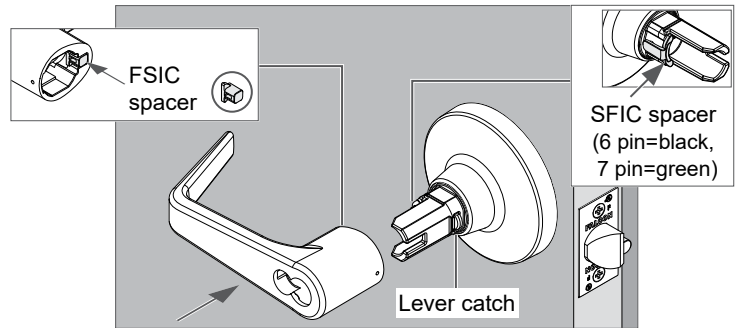

2. Install IC cylinder tailpiece. Push tailpiece until it snaps into place.

FSIC cylinder:

Align notch with cap pin.

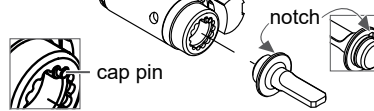

SFIC cylinder:

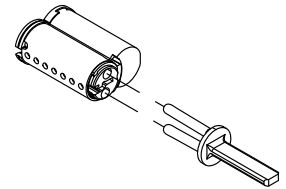

Note: TM561 and TM575 use a different outside cylinder tailpiece.

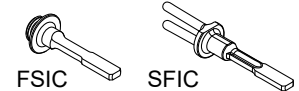

3. Insert the control key into the cylinder and rotate 15 degrees clockwise. Then, insert the cylinder assembly into the lever.

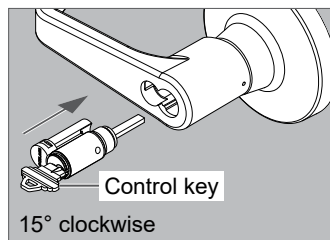

4. Rotate the control key counterclockwise until it stops and remove the key from the cylinder.

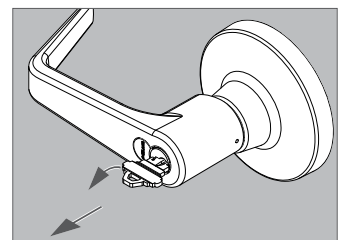

INSIDE OF LOCK

TM381 Vestibule Function ONLY

A. Install strike, latch, chassis/spring cage assembly, and inside rose as shown in steps 1 through 5 (pages 2–3).
If necessary, install outside lever and outside cylinder (see "[For Lock Less Cylinder Only](#)" on page 4).

① **NOTE:** TM381 cylinders use a short, straight tailpiece on the outside and a long, indented tailpiece inside. See page 1 for illustrations.

FOLLOW STEPS BELOW FOR APPLICABLE CYLINDER TYPE.

FOR KIL CYLINDER:

B. Adjust the **inside** cam position with timing tool:

Rotate inside cam with timing tool **clockwise** until it stops.

Then, rotate **counterclockwise** slightly.



Correct cam position

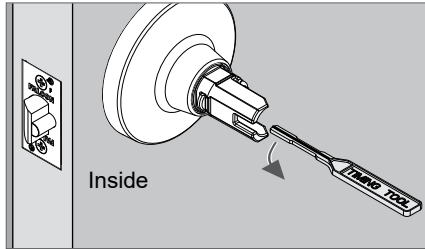

C. Place the cylinder assembly into the lever.

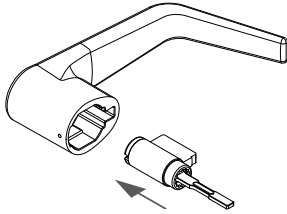

D. Insert the key and rotate **90 degrees clockwise**.

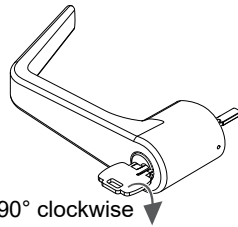

E. With key still rotated 90 degrees clockwise, push inside lever onto the spindle. Be sure to engage the lever catch.

Spacer must be installed on spindle.

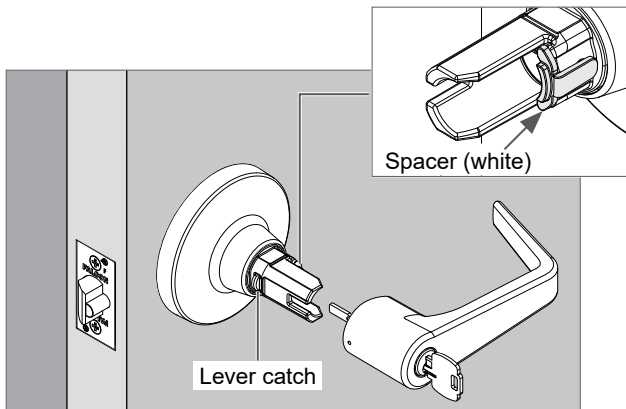

F. Rotate the key counterclockwise back to the starting position and remove the key.

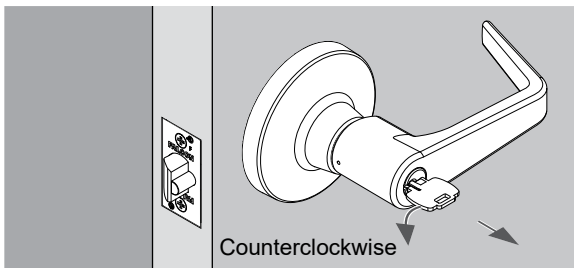

FOR IC CYLINDER:

B. If the inside lever is not installed, push the lever onto the spindle. Be sure to engage the lever catch.

Spacer must be installed.

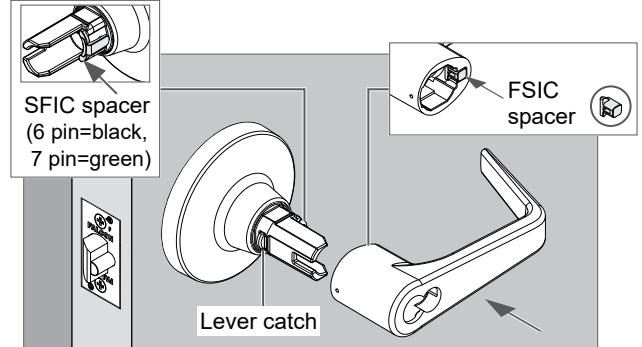

C. Adjust **inside** cam position with timing tool:

Rotate inside cam with timing tool **clockwise** until it stops.

Then, rotate **counterclockwise** approximately 180 degrees until opening is horizontal.



Correct cam position

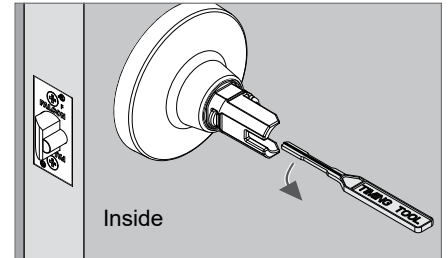

D. Install IC cylinder tailpiece. Push tailpiece until it snaps into place.

SFIC cylinder:

Align notch with cap pin.

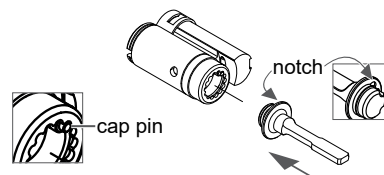

SFIC cylinder:

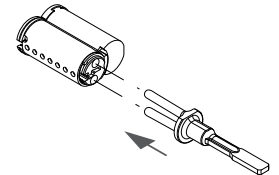

E. Insert the **control key** into the cylinder and rotate 15 degrees clockwise to retract lug.

Then, insert the cylinder assembly into the lever.

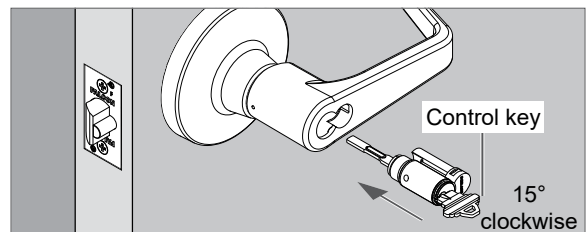

F. Rotate the key counterclockwise until it stops and remove the key from the cylinder.

TM561 Classroom Function ONLY

See other functions on previous and following pages.

A. Install strike, latch, chassis/outside spring cage assembly, and inside rose as shown in steps 1 through 5 (pages 2–3).
If necessary, install outside lever and outside cylinder (see "[For Lock Less Cylinder Only](#)" on page 4).

B. Adjust the **inside** hub position with timing tool:

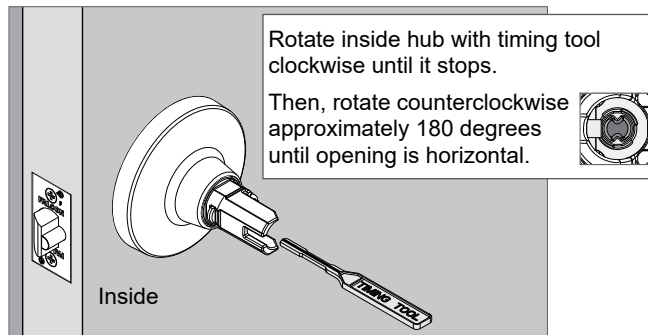

C. Install the dummy cylinder.

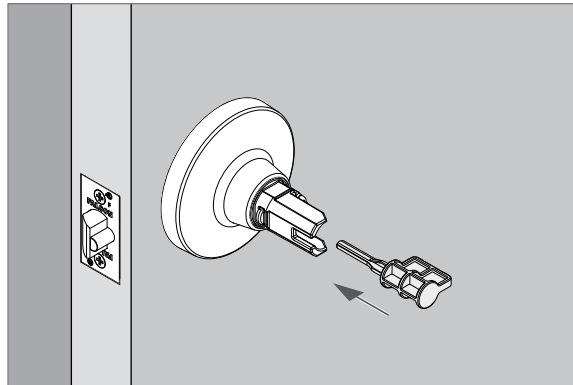

D. Push the inside lever onto the spindle.

Be sure to engage the lever catch.

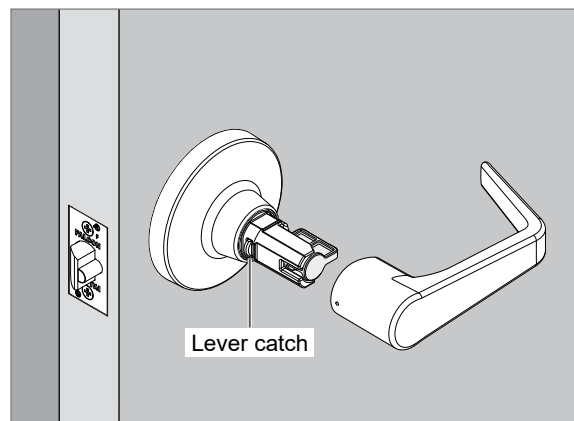

TM575 Classroom Security Function ONLY

See other functions on previous pages.

- A. Install strike, latch, chassis/outside spring cage assembly, and inside rose as shown in steps 1 through 5.
If necessary, install outside lever and outside cylinder (see "[For Lock Less Cylinder Only](#)" on page 4).

FOLLOW STEPS BELOW FOR APPLICABLE CYLINDER TYPE.

FOR KIL CYLINDER:

- B. Adjust the **inside** hub position with timing tool:

Rotate inside hub with timing tool **clockwise** until it stops.

Then, rotate **counterclockwise** slightly.



Correct hub position

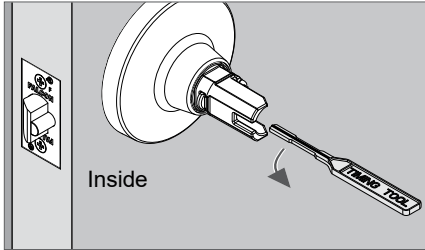

- C. Place the cylinder assembly into the lever.

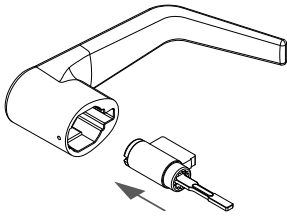

- D. Insert the key and rotate **90 degrees clockwise**.

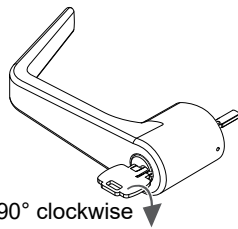

- E. With key still rotated 90 degrees clockwise, push inside lever onto the spindle. Be sure to engage the lever catch.

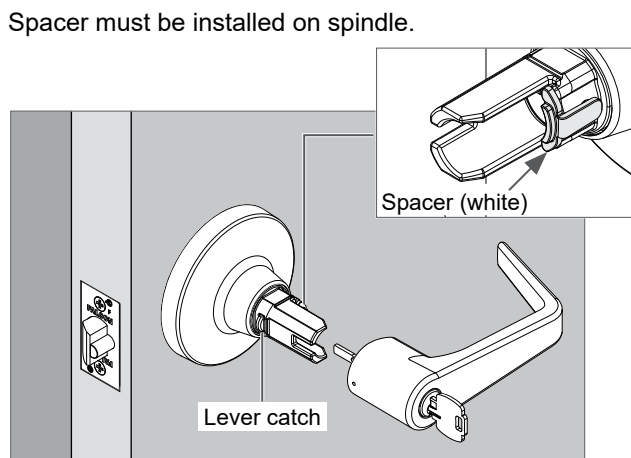

- F. Rotate the key counterclockwise back to the starting position and remove the key.

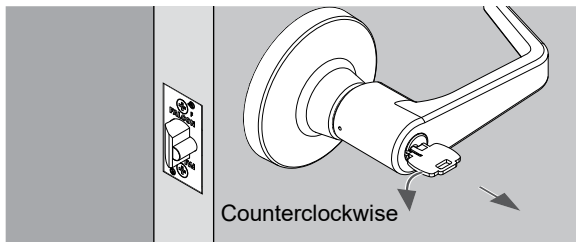

FOR IC CYLINDER:

- B. If the inside lever is not installed, push the lever onto the spindle. Be sure to engage the lever catch.

Spacer must be installed.

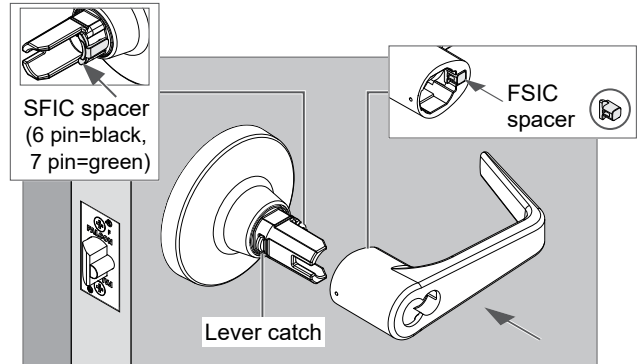

- C. Adjust the **inside** hub position with timing tool.

Rotate inside hub with timing tool **clockwise** until it stops.

Then, rotate **counterclockwise** approximately 180 degrees until opening is horizontal.



Correct cam position

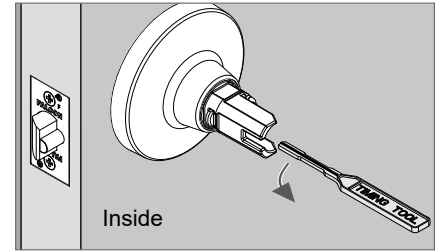

- D. Install IC cylinder tailpiece.

Push tailpiece until it snaps into place.

FSIC cylinder:

Align notch with cap pin.

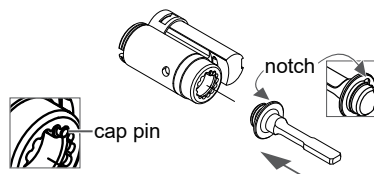

SFIC cylinder:

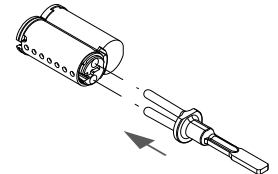

- E. Insert the control key into the cylinder and rotate 15 degrees clockwise.

Then, insert the cylinder assembly into the lever.

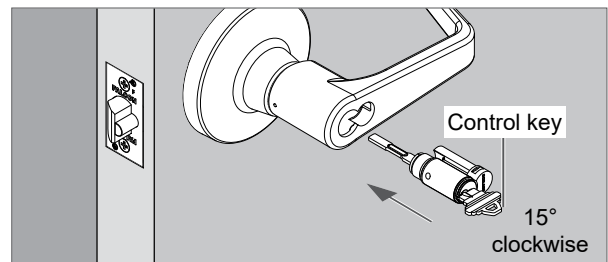

- F. Rotate the key counterclockwise until it stops and remove the key from the cylinder.

LEVER REMOVAL

Closed lever

(TM101 inside and outside, or TM561, TM581 inside)

1. Push the lever catch with the pin wrench.
2. Pull off the lever while pushing on the pin wrench.

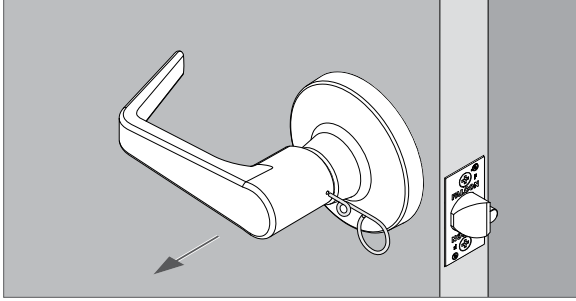

Lever with turn (TM291 or TM301, outside)

1. Push the lever catch with the pin wrench.
2. Pull off the lever while pushing on the pin wrench.

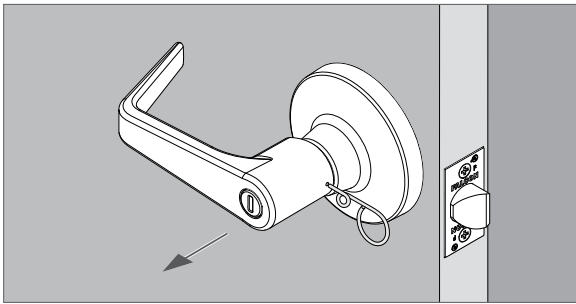

TM301 shown

Lever with KIL cylinder (inside or outside)

1. Insert key and turn 90 degrees clockwise.
2. Push the lever catch with the pin wrench.
3. Pull off the lever while pushing on the pin wrench.

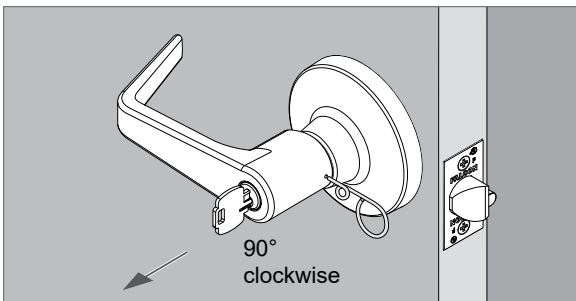

IC cylinder and IC lever (inside or outside)

1. Insert control key and turn 15 degrees clockwise.
2. Pull out the cylinder.
3. Push the lever catch with the pin wrench.
4. Pull off the lever while pushing on the pin wrench.

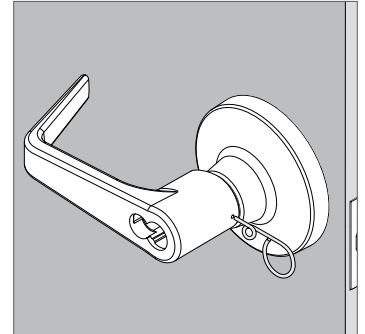
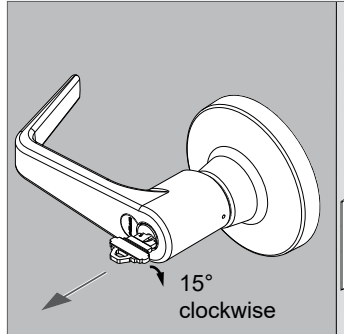

[Return to INDEX](#)

ROSE REMOVAL

1. Rotate the rose counterclockwise approximately 10°.
2. Then, remove the rose.

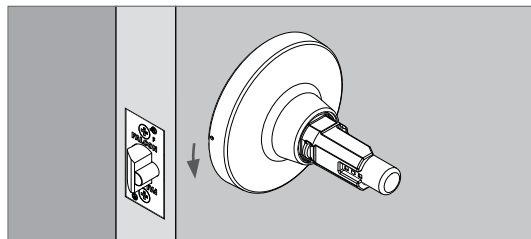

LOCK FUNCTIONAL TESTING

NOTICE

Test the lock with the door open to prevent being locked out.

TM101 Passage Function

1. Rotate inside lever. Rotation should be smooth and latch should retract.
2. Rotate outside lever. Rotation should be smooth and latch should retract.

TM301 Privacy Function

1. Push the inside button to lock the outside lever. Check that the outside lever is locked.
2. Rotate the inside lever to release the button and unlock the outside lever. Check that the outside lever is unlocked.
3. Push the inside push button to relock the outside lever. Check that the outside lever is locked.
4. Using a flat screwdriver, rotate the outside emergency turn to release the inside button. Check that the outside lever is unlocked.
5. The inside lever should always be unlocked and rotate freely.

TM291 Hospital/Privacy Function

1. Push the inside push button to lock the outside lever. Check that the outside lever is locked.
2. Rotate the inside lever to release the button and unlock the outside lever. Check that the outside lever is unlocked.
3. Push the inside push button to relock the outside lever. Check that the outside lever is locked.
4. Rotate the outside emergency turn to release the inside button. Check that the outside lever is unlocked.
5. The inside lever should always be unlocked and rotate freely.

TM381 Vestibule Function

1. Rotate the inside key 180 degrees counterclockwise (to hard stop) and back to home to lock the outside lever. Check that the outside lever is locked.
2. Use the outside key to retract the latch when the door is locked.
3. Rotate the inside key 180 degrees clockwise (to hard stop) and back to home to unlock the outside lever. Check that the outside lever is unlocked.
4. The inside lever should always be unlocked and rotate freely.

TM501 Entrance/Office Function

1. Push the inside push button to lock the outside lever. Check that the outside lever is locked.
2. Rotate the inside lever to release the button and unlock the outside lever. Check that the outside lever is unlocked.
3. Push the inside push button to relock the outside lever. Check that the outside lever is locked.
4. Use the outside key to retract the latch and release the push button. Check that the outside lever is unlocked.
5. The inside lever should always be unlocked and rotate freely.

TM511 Entrance Function

1. Push the inside push-turn button to lock the outside lever. Check that the outside lever is locked.
2. Rotate the inside lever to release the button and unlock the outside lever. Check that the outside lever is unlocked.
3. Push the inside push-turn button to relock the outside lever. Check that the outside lever is locked.
4. Use the outside key to retract the latch and release the push-turn button. Check that the outside lever is unlocked.
5. Push and turn the inside push-turn button 90 degrees clockwise to lock the outside lever. Check that the outside lever is locked.
6. Use the outside key to retract the latch. The push-turn button should stay in the locked (depressed and turned) position.
7. Rotate the inside push-turn button 90 degrees counterclockwise and then rotate the inside lever to release the inside push-turn button and unlock the outside lever. Check that the outside lever is unlocked.
8. The inside lever should always be unlocked and rotate freely.

[Return to INDEX](#)

TM561 Classroom Function

1. Rotate the outside key 225 degrees counterclockwise (to hard stop), and back to home to lock the outside lever. Check that the outside lever is locked.
2. Rotate the outside key 225 degrees clockwise (to hard stop), and back to home to unlock the outside lever. Check that the outside lever is unlocked.
3. The inside lever should always be unlocked and rotate freely.

TM571 Corridor Function

Lock by outside key:

IMPORTANT: When locked by key, the outside lever remains locked until unlocked by key.

1. Rotate the outside key 160 degrees counterclockwise (to semi-hard stop – rotate an additional 60 degrees to retract the latch), and back to home to lock the outside lever. Check that the outside lever is locked.
2. Rotate the outside key 180 degrees counterclockwise to release the push button, retract the latch and lock the outside lever by key. Check that the outside lever is locked.
3. Rotate the outside key 180 degrees clockwise (to hard stop) and back to home to unlock the outside lever. Check that the outside lever is unlocked.

Lock by inside push button:

IMPORTANT: To keep the outside lever locked, it must be locked by key as described above.

If not locked by key, the outside lever will unlock when the inside lever is unlocked as described below.

NOTE: Before performing the following tests, check that the outside lever is unlocked by key as described above.

1. Push the inside push button to lock the outside lever. Check that the outside lever is locked.
2. Rotate the inside lever to release the push button and unlock the outside lever. Check that the outside lever is unlocked.
3. With the door open, push the inside push button to relock the outside lever. Check that the outside lever is locked.
4. Close the door or push in latch bolt to release the inside push button and unlock the outside lever. Check that the outside lever is unlocked.
5. Push the inside push button to relock the outside lever. Check that the outside lever is locked.
6. Rotate the outside key 225 degrees clockwise to release the push button, retract the latch and unlock the lock. Check that the locked is unlocked.
7. The inside lever should always be unlocked and rotate freely.

TM575 Classroom Security Function

1. Using either the inside or outside key, rotate key 225 degrees counterclockwise (to hard stop), and back to home to lock the outside lever. Check that the outside lever is locked.
2. Using either the inside or outside key, rotate key 225 degrees clockwise (to hard stop), and back to home to unlock the outside lever. Check that the outside lever is unlocked.

TM581 Storeroom Function

1. Check that the outside lever is locked.
2. Use the outside key to retract the latch.
3. The inside lever should always be unlocked and rotate freely.

[Return to INDEX](#)

Customer Service (U.S.)

1-877-671-7011

www.allegion.com/us

Customer Service (Canada)

1-800-900-4734

www.allegion.ca